



## EXERGY UNVEILS GEMINI TURBINE: THE NEW FRONTIER IN LARGE-SCALE GEOTHERMAL POWER GENERATION

- ***New milestone in Exergy's Radial Outflow Turbine (ROT) technology, boosting power output to 60 MWe on a single shaft***
- ***A competitive, high-efficiency solution for next-generation large-scale geothermal systems***

**Olgiate Olona, 27 October 2025** – Exergy International, a global leader in advanced geothermal binary power plants, today unveiled a new milestone in its proprietary **Radial Outflow Turbine (ROT)** technology: the **Gemini Turbine**.

This innovative configuration combines the power of two turbines into a single high-capacity unit delivering up to **60 MWe**. Conceived and developed entirely in-house by Exergy's Turbine team in Italy, the Gemini sets a new benchmark for **efficiency, scalability, and competitiveness** in large-scale geothermal power generation, making it the ideal match for next-generation **Enhanced and Advanced Geothermal Systems** (EGS and AGS).

### **A New Architecture for Maximum Performance**

At the heart of Gemini's innovation lies an evolution of Exergy's proprietary ROT architecture. The turbine features a **dual-inlet design** that allows the working fluid to enter symmetrically from both sides and expand radially outward through a central rotor disk equipped with dual mirrored rotor stages. After its radial expansion, the fluid converges toward a central exhaust flange for discharge.

In this new configuration, stator blades are mounted on lateral stator disks, while the rotor is supported in a **between-bearings arrangement**, replacing the traditional overhung setup. This structural advancement significantly enhances the turbine's **mechanical stability**, reduces vibration, and improves operational reliability.

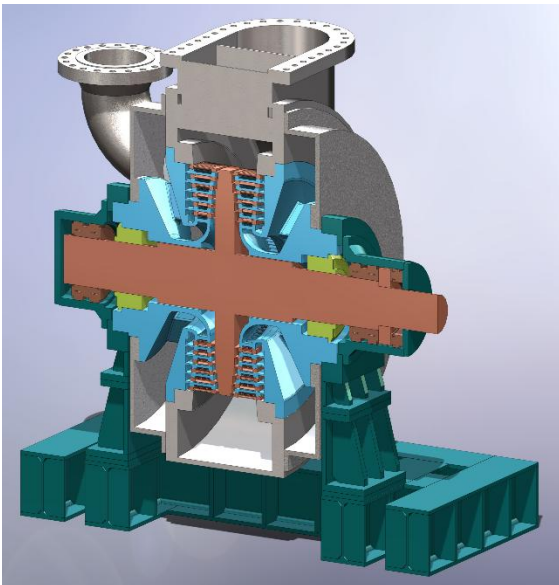

3D section of the Gemini Turbine

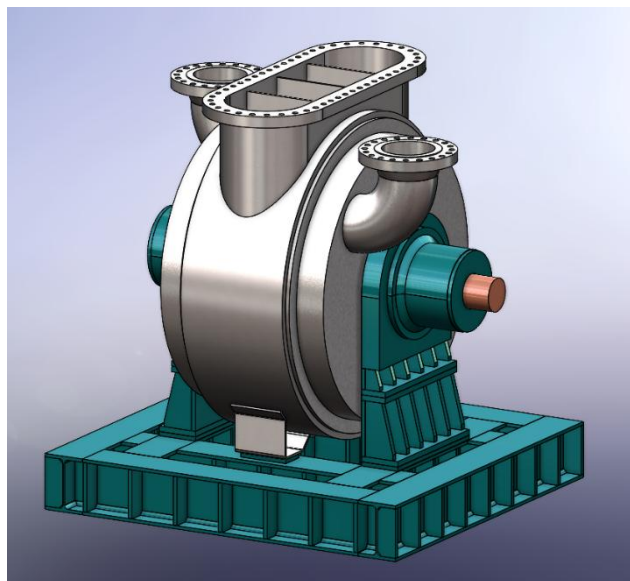

3d model of the Gemini Turbine



## Advantages and Key Benefits

The Gemini turbine's unique configuration delivers a series of **technical, operational** and **economic advantages** providing real value for developers and operators:

- Capability to handle **very high volumetric flows** (exceeding 50 m<sup>3</sup>/s) on a single shaft
- **Isentropic efficiency above 90%**, equivalent to multi-turbine systems in one compact machine
- **Simplified plant layout** and reduced mechanical complexity
- **Shaft locking system allowing easy and fast maintenance**
- **Reliability** based on Exergy's **proven ROT technology** (>550 MWe installed worldwide)
- Up to **30% lower power plant cost** than conventional multi-turbine configurations
- Reduced erection and civil-works with **smaller footprint** and **higher sustainability**
- Improved project economics with **faster return on investment** (ROI)

**Luca Pozzoni, Deputy CEO of Exergy International** commented: "The Gemini turbine marks a major milestone in Exergy's technological evolution. It showcases the strength of our engineering expertise and the creativity of our team, who constantly push the boundaries of what our technology can achieve. With Gemini, we deliver a solution that offers higher performance, lower costs, and a reduced environmental footprint — all essential for the future of large-scale geothermal power".

**Luca Vanini, Manager of Exergy's Turbine department** added: "Continuous improvement is a key principle at Exergy. Rooted in an idea by our Turbine Engineer Giorgia Ruffato, the project of the Gemini was developed within our turbine department and refined through close collaboration across all our technical teams. It's an achievement that reflects both our innovation culture and our commitment to practical, high-performance solutions. Seeing it come to life is a proud moment for everyone involved".

## Applications and Market Outlook

The Gemini Turbine opens new possibilities for harnessing geothermal resources with **very high flow rates** more efficiently, replacing traditional configurations that use two ROT turbines operating in parallel. It provides a **competitive, cost-effective**, and **high-performance** solution for large-scale geothermal power plants in the **30–60 MW range**.

Gemini is particularly suited to **next-generation geothermal systems** based on EGS and AGS technologies, which are emerging as the most promising frontier of global geothermal development. These systems enable power generation in regions previously considered unsuitable for geothermal use.

Since 2017, investment in next-generation geothermal technologies has risen sharply — from negligible levels to nearly US\$2 billion raised in 2024 (Wood Mackenzie)— driven by both private and public sector support. According to the International Energy Agency, global geothermal capacity could exceed 800 GW by 2050, supplying around 8% of the world's electricity —confirming geothermal energy as a key pillar in the world's clean-energy future.

### ABOUT EXERGY INTERNATIONAL SRL

EXERGY INTERNATIONAL Srl is a leading provider of clean energy technologies. We are experts in the design, engineering and manufacturing of Organic Rankine Cycle (ORC) systems with the pioneering Radial Outflow Turbine. EXERGY's proprietary technologies, covered by several patents, allow for highly efficient energy production via the exploitation of heat sources from geothermal, waste heat from industry, biomass and concentrated solar power. The EXERGY portfolio accounts for almost 600 MWe and the second largest geothermal binary fleet worldwide. EXERGY is part of TICA Group, a leading integrated system and service provider in HVAC. From the headquarters in the north of Italy (Milan), EXERGY exports and implements its technology worldwide with a particular focus on high growth potential markets. Website: <https://exergy-orc.com/>

### PRESS CONTACT

EXERGY INTERNATIONAL

Sara Milanesi

Marketing & Communications Manager

Tel.: +39 0331 1817620

Mobile: +39 3666012588

[s.milanesi@exergy.it](mailto:s.milanesi@exergy.it)